

1N4896(A)-1N4915(A)

TEMPERATURE COMPENSATED ZENER DIODES

FEATURES

- Available as "HR" (high reliability) screened per MIL-PRF-19500, JANTX level. Add "HR" suffix to base part number.
- Available as non-RoHS (Sn/Pb plating), standard, and as RoHS by adding "-PBF" suffix.

MAXIMUM RATINGS

Characteristics	Symbol	Value	Unit
Operating and storage temperature	T_J, T_{STG}	-65 to +175	°C
Thermal resistance, junction to lead @ 0.375" from body	$R_{\theta JL}$	300	°C/W
Off state power dissipation @ $T_A = 50^\circ\text{C}$ (1)	P_D	500	mW
Maximum reverse current @ $T_A = 25^\circ\text{C}$ and $V_R = 8\text{V}$	I_{RM}	15	μA
Solder temperature @ 10s	T_{SP}	260	°C

Note 1: Derate at 4mW/°C above $T_A = 50^\circ\text{C}$.

ELECTRICAL CHARACTERISTICS ($T_A = 25^\circ\text{C}$ unless otherwise specified)

Part number	Test current (Notes 1 & 5)	Maximum voltage change with temperature (Notes 2 & 5)	Temperature range	Effective temperature coefficient (Note 3)	Maximum dynamic impedance (Note 4)	Maximum noise density
	I_{ZT}	ΔV_Z		α_{VZ}	Z_{ZT}	N_D
	mA	Volts	°C	$\pm\%/^\circ\text{C}$	Ohms	$\mu\text{V}/\sqrt{\text{Hz}}$
1N4896	0.5	0.096	To +100	0.01	400	0.8
1N4896A	0.5	0.198	-55 to +100	0.01	400	0.8
1N4897	0.5	0.048	+25 to +100	0.005	400	0.8
1N4897A	0.5	0.099	-55 to +100	0.005	400	0.8
1N4898	0.5	0.019	+25 to +100	0.002	400	0.8
1N4898A	0.5	0.040	-55 to +100	0.002	400	0.8
1N4899	0.5	0.010	+25 to +100	0.001	400	0.8
1N4899A	0.5	0.20	-55 to +100	0.001	400	0.8
1N4900	1.0	0.096	+25 to +100	0.01	200	0.4
1N4900A	1.0	0.198	-55 to +100	0.01	200	0.4
1N4901	1.0	0.048	+25 to +100	0.005	200	0.4
1N4901A	1.0	0.099	-55 to +100	0.005	200	0.4
1N4902	1.0	0.019	+25 to +100	0.002	200	0.4
1N4902A	1.0	0.040	-55 to +100	0.002	200	0.4
1N4903	1.0	0.010	+25 to +100	0.001	200	0.4
1N4903A	1.0	0.020	-55 to +100	0.001	200	0.4
1N4904	2.0	0.096	+25 to +100	0.01	100	0.25
1N4904A	2.0	0.198	-55 to +100	0.01	100	0.25
1N4905	2.0	0.048	+25 to +100	0.005	100	0.25
1N4905A	2.0	0.099	-55 to +100	0.005	100	0.25
1N4906	2.0	0.019	+25 to +100	0.002	100	0.25
1N4906A	2.0	0.040	-55 to +100	0.002	100	0.25

1N4896(A)-1N4915(A)

TEMPERATURE COMPENSATED ZENER DIODES

ELECTRICAL CHARACTERISTICS ($T_A = 25^\circ\text{C}$ unless otherwise specified)

Part number	Test current (Notes 1 & 5)	Maximum voltage change with temperature (Notes 2 & 5)	Temperature range	Effective temperature coefficient (Note 3)	Maximum dynamic impedance (Note 4)	Maximum noise density
	I_{ZT}	ΔV_Z		α_{VZ}	Z_{ZT}	N_D
	mA	Volts	$^\circ\text{C}$	$\pm\%/^\circ\text{C}$	Ohms	$\mu\text{V}/\sqrt{\text{Hz}}$
1N4907	2.0	0.010	+25 to +100	0.001	100	0.25
1N4907A	2.0	0.020	-55 to +100	0.001	100	0.25
1N4908	4.0	0.096	+25 to +100	0.01	50	0.22
1N4908A	4.0	0.198	-55 to +100	0.01	50	0.22
1N4909	4.0	0.048	+25 to +100	0.005	50	0.22
1N4909A	4.0	0.099	-55 to +100	0.005	50	0.22
1N4910	4.0	0.019	+25 to +100	0.002	50	0.22
1N4910A	4.0	0.040	-55 to +100	0.002	50	0.22
1N4911	4.0	0.010	+25 to +100	0.001	50	0.22
1N4911A	4.0	0.020	-55 to +100	0.001	50	0.22
1N4912	7.5	0.096	+25 to +10	0.01	25	0.20
1N4912A	7.5	0.198	-55 to +100	0.01	25	0.20
1N4913	7.5	0.048	+25 to +10	0.005	25	0.20
1N4913A	7.5	0.099	-55 to +100	0.005	25	0.20
1N4914	7.5	0.019	+25 to +10	0.002	25	0.20
1N4914A	7.5	0.040	-55 to +100	0.002	25	0.20
1N4915	7.5	0.010	+25 to +10	0.001	25	0.20
1N4915A	7.5	0.020	-55 to +100	0.001	25	0.20

Note 1: Nominal voltage for all types 12.8V $\pm 5\%$.

Note 2: Referred to as "box" measurement method, ΔV_Z is the minimum voltage variance that will occur as the voltage is scanned through all temperatures between the temperature range limits.

Note 3: The effective temperature coefficients are tabulated in $\%/^\circ\text{C}$ primarily for information only since temperature compensated diodes inherently have a non-linear voltage temperature characteristic.

Note 4: The dynamic zener impedance Z_{ZT} is derived from the resulting AC voltage developed when a 60vps, rms AC current equal to 10% of the DC zener current I_{ZT} is superimposed on I_{ZT} .

Note 5: Voltage measurements to be performed 15 seconds after application of DC current.

1N4896(A)-1N4915(A)

TEMPERATURE COMPENSATED ZENER DIODES

MECHANICAL CHARACTERISTICS

Case:	DO-35
Marking:	Body painted, alpha-numeric
Polarity:	Cathode band

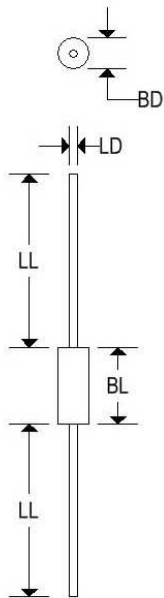

	DO-35			
	Inches		Millimeters	
	Min	Max	Min	Max
BD	0.055	0.090	1.400	2.290
BL	0.120	0.200	3.050	5.080
LD	0.018	0.022	0.460	0.560
LL	1.000	1.500	25.400	38.100

1N4896(A)-1N4915(A)

TEMPERATURE COMPENSATED ZENER DIODES

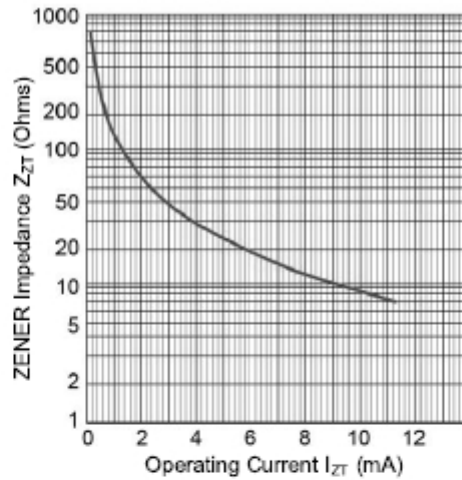

FIGURE 1
Zener Impedance vs. Operating Current
(1N4896 thru 1N4915A)

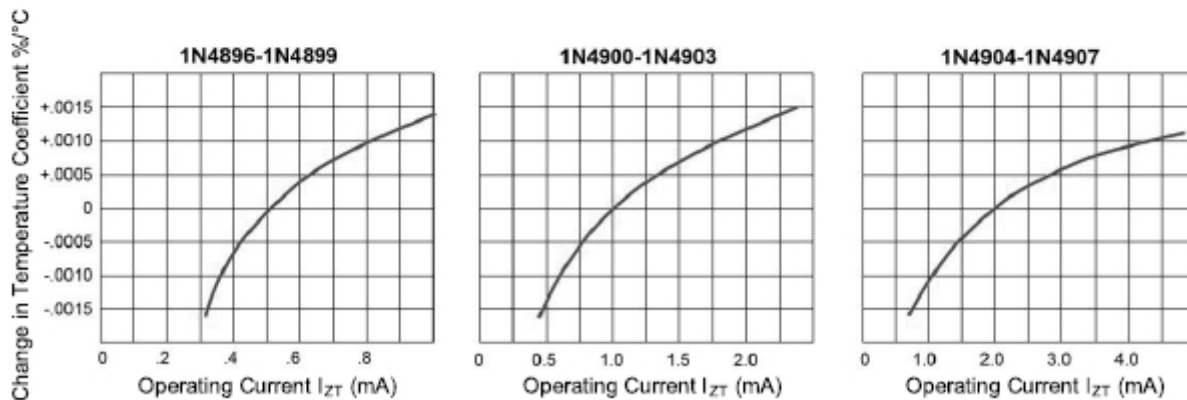

FIGURE 2
Typical Change of Temperature Coefficient with Change in Operating Current

1N4896(A)-1N4915(A)

TEMPERATURE COMPENSATED ZENER DIODES

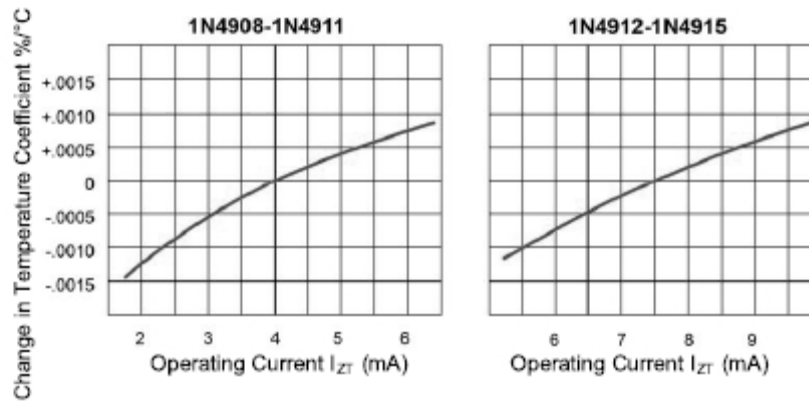

FIGURE 2 (continued)
Typical Change of Temperature Coefficient with Change in Operating Current

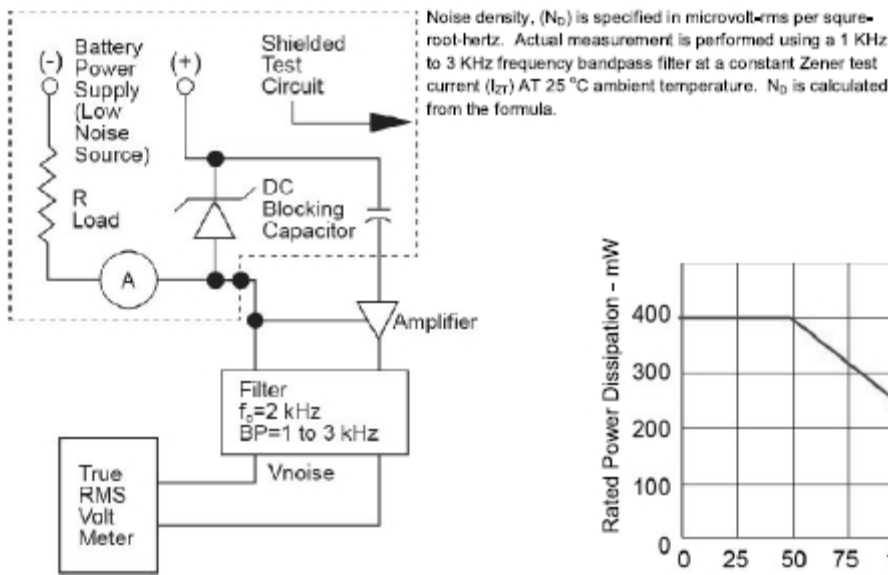

FIGURE 3
Noise Density Measurement Circuit

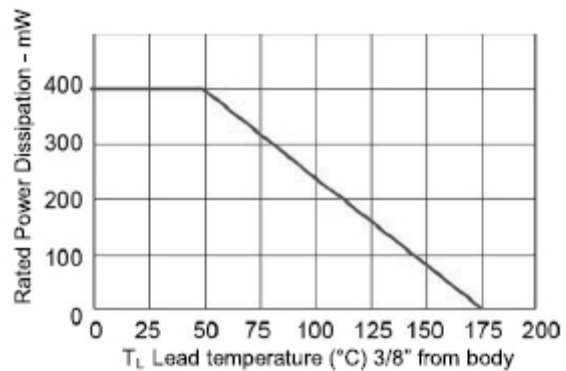

FIGURE 4
Power Derating Curve